

ITEM NO.	P/N	DESCRIPTION	QTY.
1	BPWV	BASE	1
2	NKSL-58	Support	1
3	HB1T-1	HUB	1
4	NKSL-78	Connector	2
5	BL1T-34	End Ball	1
6	NKSL-1.25	Neck	1
7	BL1T-12	Small End Ball	1
8	DSFL-2.375	PLATE	1
9	TU12-6	PIPE	1

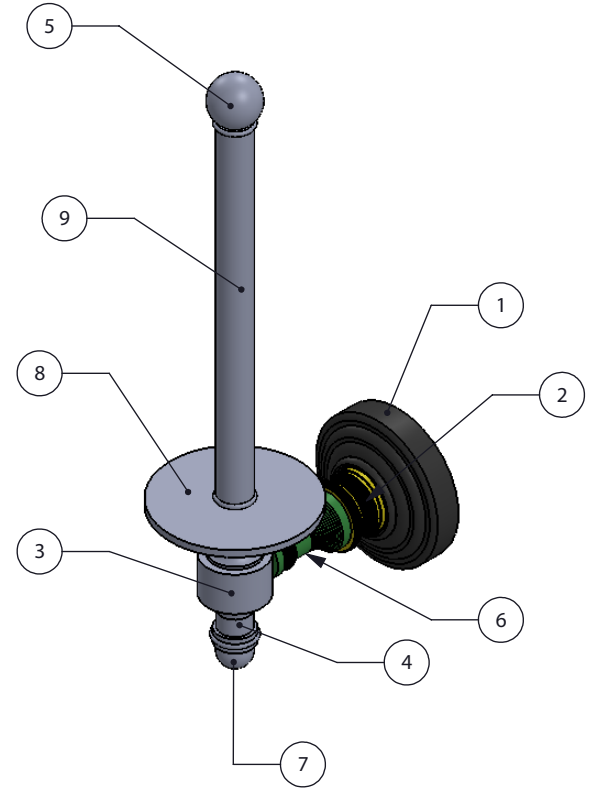

**CONFIDENTIALITY/LIMITED LIABILITY STATEMENT**  
 This document (and any files attached to it) is confidential and intended only for the person or entity to which it is delivered. If you are not the intended recipient, then you have received this document by mistake and any use, dissemination, forwarding, printing or copying of this document and its file attachments is prohibited. Please notify ALLIED BRASS INC. immediately either by telephone or by email, delete the misdirected document from your system and destroy any copies you have made of it. We do not accept any liability for any loss or damage which may arise from your receipt of this document.

UNLESS OTHERWISE STATED				INITIALS	DATE	ITEM	QTY	DRG/PART NO	CLIENT:			
DO NOT SCALE	X.XXX	±0.025	DESIGNED	IJM	MATERIAL	BRASS		WEIGHT	FINISH		TBD	
DRAWING	X.XX	±0.1	DRAWN	IJM	HEAT TREAT	NA		QUANTITY				
CHAMFER ALL	X.X	±0.25	CHECKED	R. ANDRIS	CUSTOMER			CUSTOMER No		---		
EDGES 0.5X4*	X	±0.75	PROJ.ENG		DESCRIPTION:		RW-24U		DRAWING No.		REV	
DRAWING ISO	X.XX	±0.05*	SAFETY				RW-24U		RW-24U		0	
	X.X	±0.1*	APPROVED	R. ANDRIS			RW-24U		SCALE		1:1	
	X	±0.5*	FILENAME	RW-24U			RW-24U		SHEET: 01		A4	
		3.2										

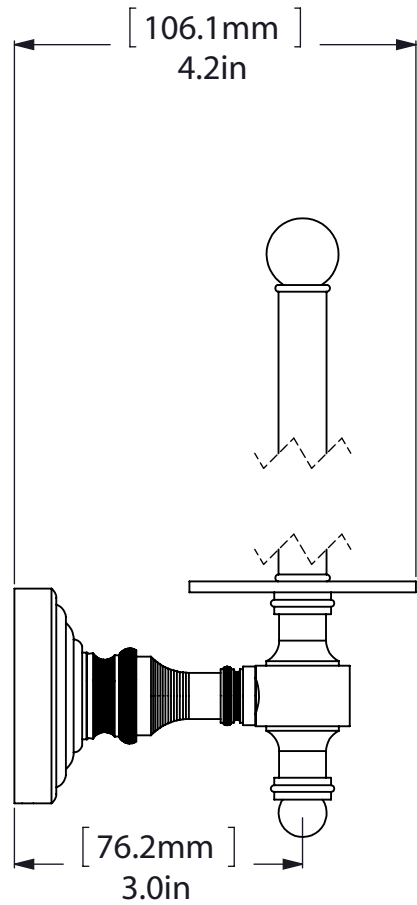
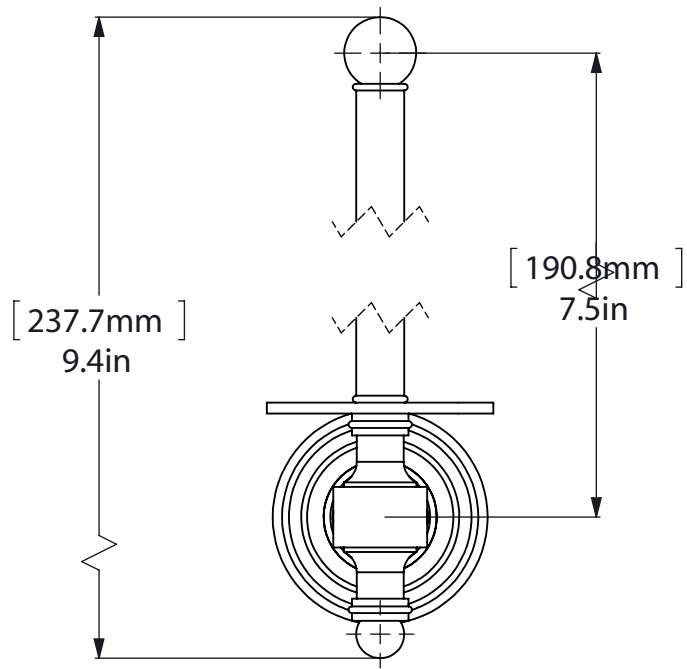